

VSP(VPR) Series Secondary Pulverizers

Designed for secondary processing to remove rebar and size concrete.
 Rotation model, 360 degree hydraulic, increases productivity.
 Large model selection is available for most carriers.

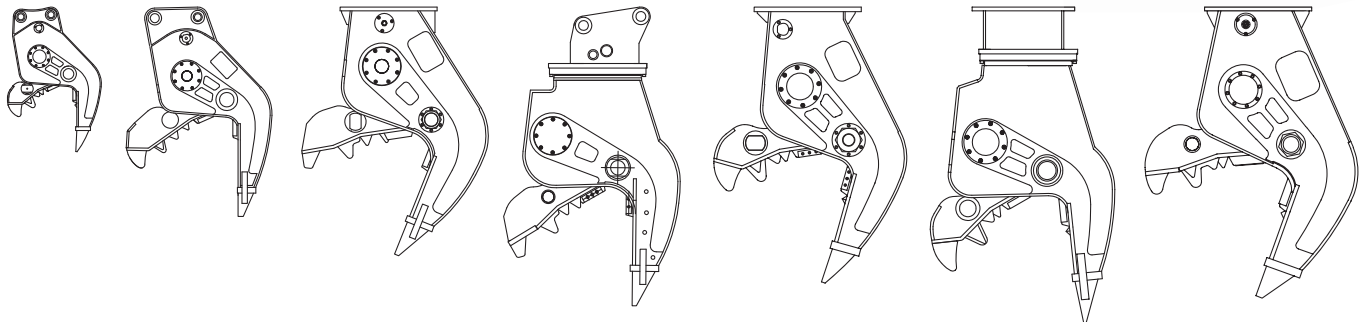

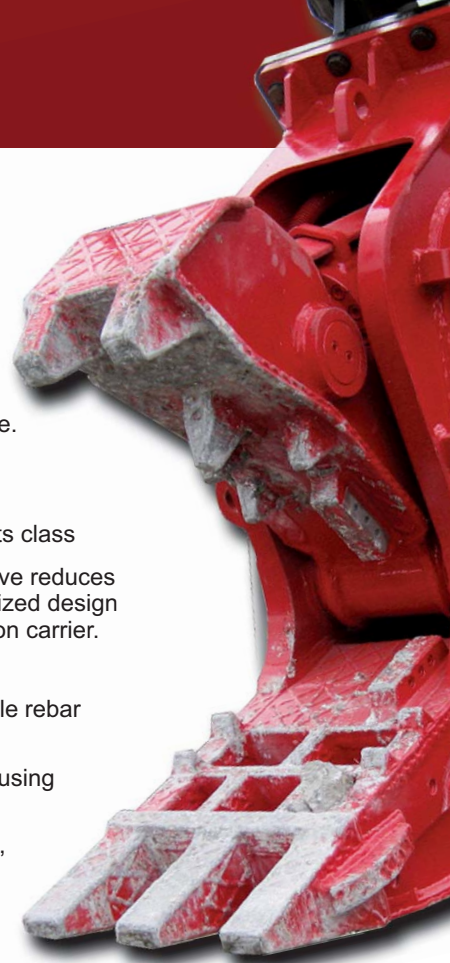
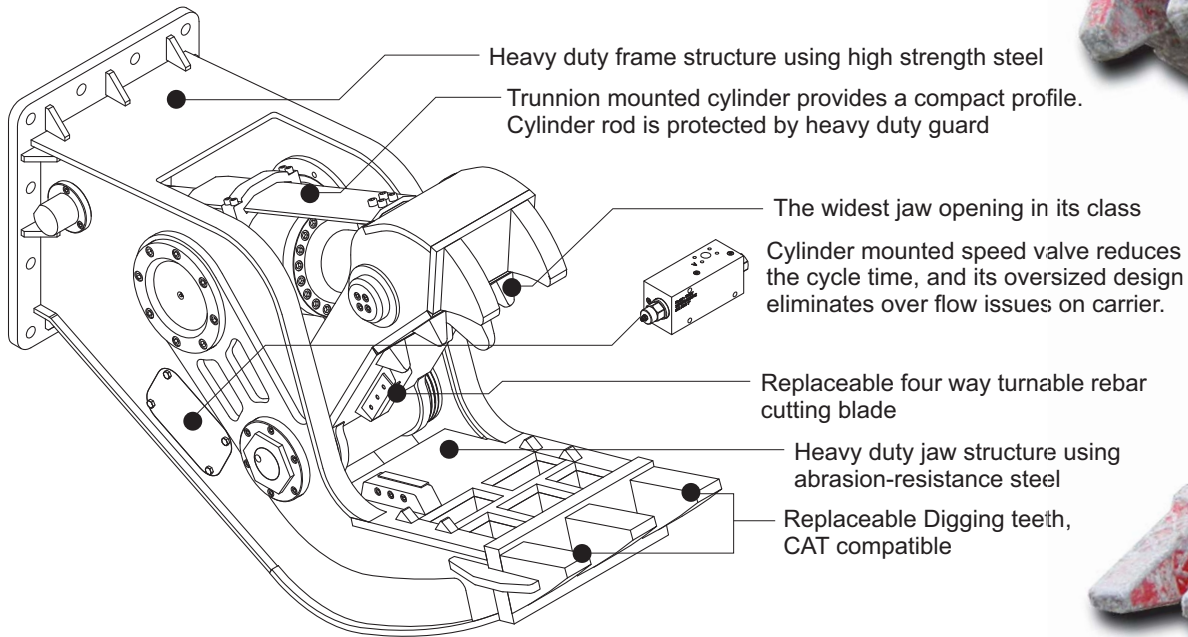
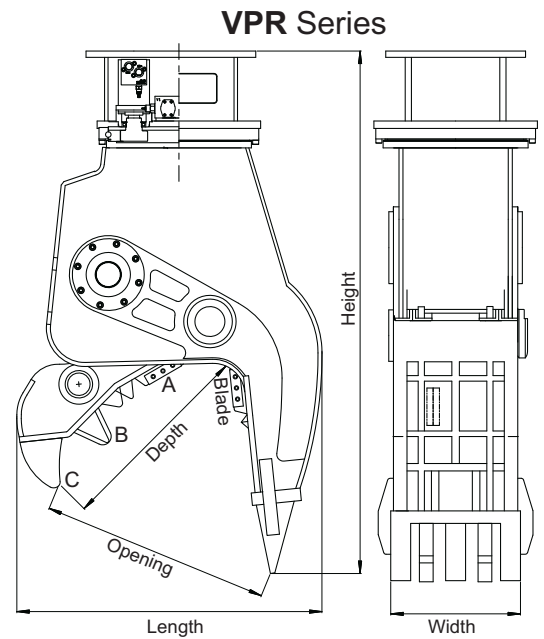
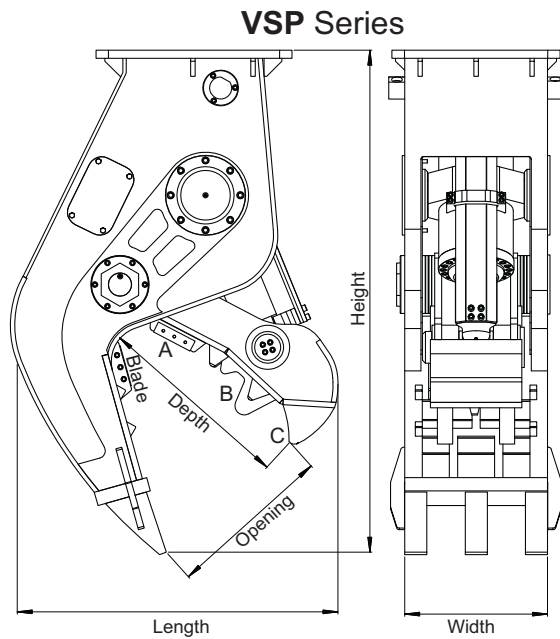

Model	Unit	VSP 052	VSP 122	VSP 152	VPR 152	VSP 182	VPR 182	VSP 202	VSP 302	Unit	VSP 052	VSP 122	VSP 152	VPR 152	VSP 182	VPR 182	VSP 202	VSP 302	
Carrier Weight	M/T	2~5	7~12	10~20	12~20	17~25	20~30	23~40	24~40	M/T	2~5	7~12	10~20	12~20	17~25	20~30	23~40	24~40	
Operating Weight	kg	250	570	950	1,150	1,500	1,850	1,950	2,450	lb	550	1,270	2,090	2,530	3,300	4,070	4,290	5,390	
DIM	Height	1,020 1,380 1,650 1,850 1,830 2,090 1,960 2,200								inch	40 54 65 73 72 82 77 87								
	Length	620 960 1,230 1,170 1,250 1,250 1,420 1,620								inch	24 38 48 46 49 49 56 64								
	Width	260 355 436 520 520 520 540 600								inch	10 14 17 20 20 20 21 24								
Jaw Opening	mm	440 700 790 790 850 920 935 1,100								inch	17 28 31 31 33 36 37 43								
Jaw Depth		395 680 820 820 825 865 870 990									16 27 32 32 32 34 34 39								
Blade Length		75 102 140 140 150 150 200 200									3.0 4.0 5.5 5.5 6.0 6.0 7.9 8								
Cutting Force [A]	M/T (Metric Ton)	37 87 163 163 191 186 202 257								lb (X1000)	80 192 359 359 420 409 445 566								
Crushing Force		[B] Mid	17 34 67 67 91 84 95 121								37 74 147 147 200 185 209 266								
		[C] Tip	11 21 42 42 60 54 62 79								24 46 93 93 132 119 137 174								
Rated Pressure	bar	250				320				psi	3,600				4,600				
Rated Oil Flow	lpm	45	80	160		280				gpm	12	21	42		74				
Hyd. Rotation	Pressure	bar	-	-	-	210	-	210	-	-	psi	-	-	-	3,000	-	3,000	-	-
	Oil Flow	lpm	-	-	-	28~32	-	40~45	-	-	gpm	-	-	-	7~8	-	10~14	-	-
	Speed	RPM	-	-	-	10~15	-	10~15	-	-	RPM	-	-	-	10~15	-	-	-	-
Cycle time	Open	sec	1.3	2.0	2.1	1.9	2.9	2.9	2.2	2.6	sec	1.3	2.0	2.1	1.9	2.9	2.9	2.2	2.6
	Close		1.3	2.6	1.9	1.8	3.0	3.0	1.9	3.4	sec	1.3	2.6	1.9	1.8	3.0	3.0	1.9	3.4

Specifications subject to change without notice.

- VPR model comes come with continuous 360degreee hydraulic rotation.
- Height : Flat Top Mounting
- Cycle Time : Measured at rated flow under no load.