

HO-PAC[®] 4000 RAMMER COMPACTOR



Faster, less expensive technique for driving wood, steel and aluminum sheeting, 'H' and 'I' beams, piling, posts and seawalls

Also great for compacting waste materials and breaking up frozen coal

Able to compact in densities in excess of 95% Proctor

Ideal for trench, slope and excavation compaction

Four Function Valve controls flow, pressure, regenerations and oil flow direction

Optional swivel-top mounting bracket permits precise positioning of Ho-Pac without repositioning the carrier

Tough coat hoses prevent cuts and extend wear life

Oil splash lubrication provides maintenance free (no greasing) bearing lubrication

HO-PAC COMPACTOR DRIVERS

Ho-Pac compactor drivers save you time, money, and increase productivity by expanding versatility and eliminating the need for special purpose machines. Ho-Pac models use an eccentric, rotating weight that creates vibrations and impulse energy for effective soil compaction and are extremely efficient at driving piling, posts, pipe, guardrails posts, etc.

HO-PAC[®] 4000

SPECIFICATIONS

Impulse Force (lbs)	40,000
Operating Frequency (rpm)	2,100
Hydraulic Flow Options (gpm)	62/86
Operating Pressure (psi)	2,200/2,200
Overall Height (inch)	39
Compaction Plate Dimensions (inch)	42 x 60
Compaction Area (sq ft)	14.0
Mounting Bracket Type	LR9
Working Weight ¹ (lbs)	4,900
Carrier Weight Class ² (1,000 lbs)	77-150

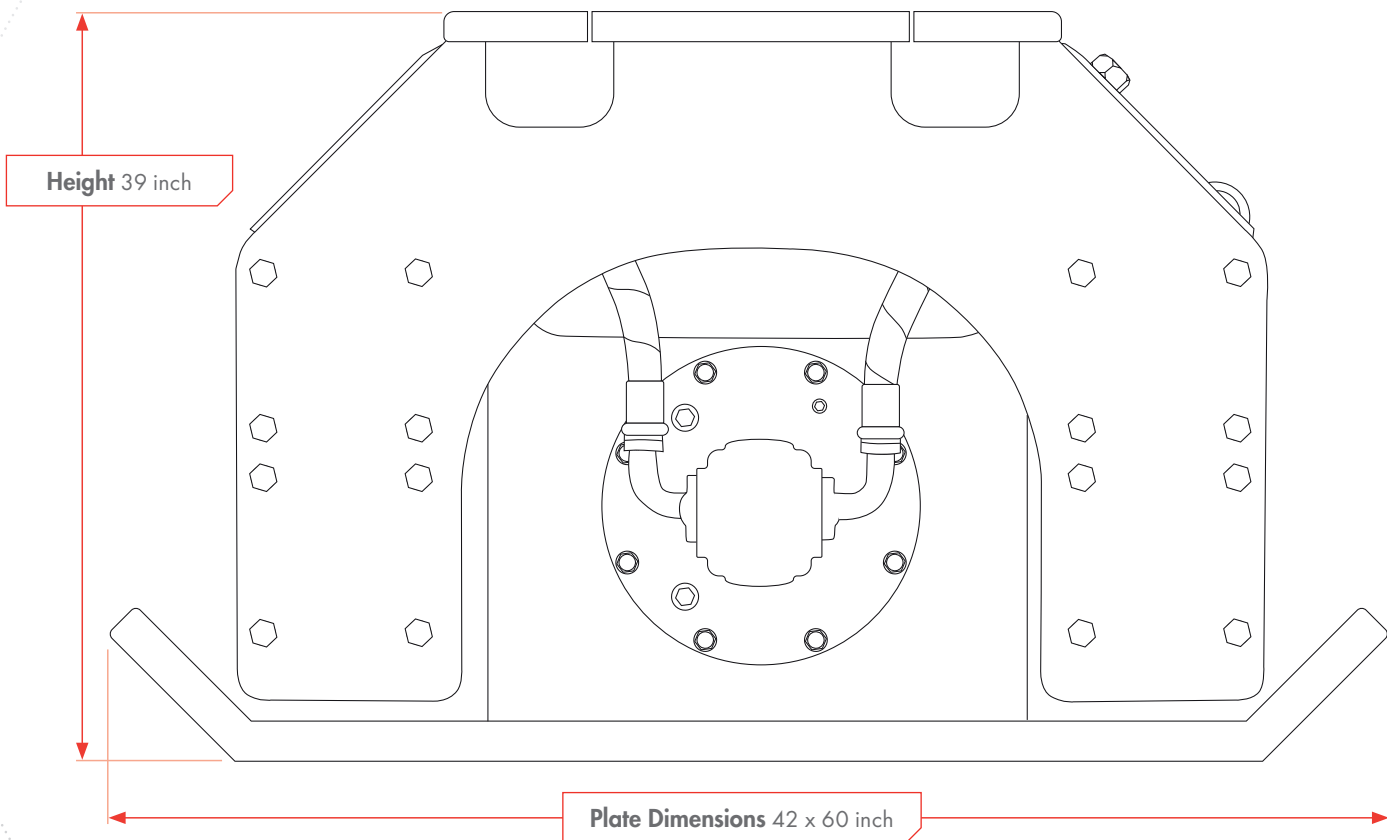

¹ Weight of compactor with typical mounting bracket

² Use as guideline only. Verify carrier's lifting and hydraulic capabilities.

Sandvik Rock Processing Solutions North America
Cleveland, OH 44114
Phone (216) 431-2600
rammer.com

Rammer[®]