

Rammer® E04

EXCELLENCE LINE COMPACT RANGE HAMMER



Rammer's world-renowned Excellence line completes with the Compact range hammers, which offer versatile, reliable solutions for construction applications.

APPLICATIONS



Excavation



Building Construction

MAIN FEATURES AND BENEFITS

THE MOST EFFICIENT OPERATIONS:

- CBE enables plug-and-play installation
- High uptime and easy maintenance based on membrane accumulator
- Compact, right size for the job – optimized fuel consumption

LONG LIFETIME AND SUITABILITY FOR DIFFERENT APPLICATIONS:

- Durability based on the highest quality materials and cast body protection by optional wear plates
- Modular body design structure enables versatile use through the whole lifecycle



The hammer in the picture is equipped with optional: wear plates, automatic greasing device, RD3

Rammer® E04

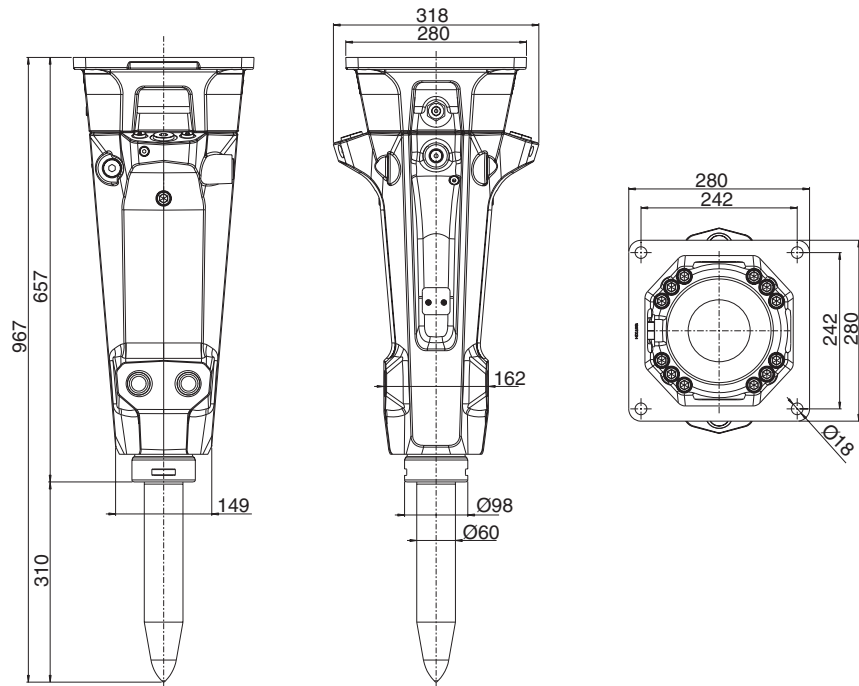

Specifications

Minimum working weight	150 kg (331 lb)
Minimum working weight with greasing device	173 kg (381 lb)
Impact rate	600...1800 bpm
Operating pressure	120...160 bar (1740...2320 psi)
Pressure relief, max	220 bar (3190 psi)
Oil flow range	20...62 l/min (5.3 gal/min...16.4 gal/min)
Back pressure, max	30 bar (435 psi)
Input power	16.5 kW (22 hp)
Tool diameter	60 mm (2.36 in)
Mini Excavator weight, allowed range	2.0...6.0 t (4400...13200 lb)
Skid steer, robot weight, allowed range	1.2...4.0 t (2600...8800 lb)

Specifications are subject to change without notice



Developed and tested in the harshest of conditions, the foundations of Rammer products are quality, operational reliability and maximized productivity. Long working life and durability ensure our attachments can be used efficiently and economically no matter the challenge at hand, making Rammer a sustainable choice.

Sandvik Mining and Construction Oy

www.rammer.com

Rammer®