

## CRUSHER BUCKET

# BF135.8

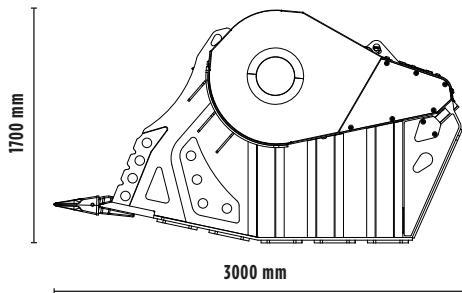

## SPECIFICATIONS

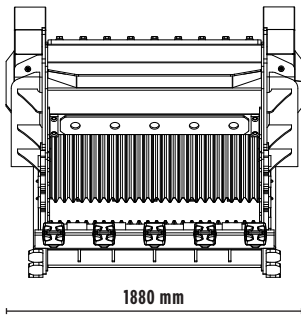

Recommended excavator	ton	43 - 80
Weight	ton	7,50
Load capacity	m <sup>3</sup>	1,80
Pressure	bar	230 - 280
Back pressure	bar	< 10
Oil flow rate*	l/min	320 - 380
Mouth width	mm	1300
Mouth height	mm	600

\* The minimum hydraulic flow rate value must be alongside the required operating pressure.

## ACCESSORIES

Dust suppression kit	Hour meter
Iron separator	24 month warranty

## APPLICATION AREAS



DENOLITIONS



ROAD WORKS



QUARRIES



MINES



PIPELINES



RECYCLING AGGREGATES



FOUNDRIES



FOREST MAINTENANCE