

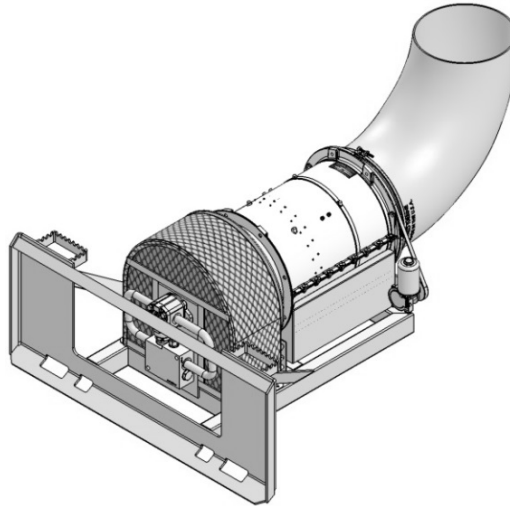

180 Zoar Valley Road • Springville, NY 14141 • Tel: (716) 592-2700 • Fax: (716) 592-2460 • BuffaloTurbine.com



Hydraulic Debris Blower Model # BT-HYSS3HS

Warranty	10 Year Manufacturer Warranty
Motor Warranty	2 Year Warranty
Input Power	Hydraulic motor
Input RPM	Up to 4100 RPM*
Outlet Size	12"
Frame Length	39"
Overall Length with Nozzle	64"
Width	46"
Max Height with nozzle in upright position	32"
Weight	300 lbs.
Nozzle Rotation	360°
Hydraulic Motor Displacement size	.915 cu.in./Rev
Required minimum hydraulic pressure (to operate @ stated values)	3100 psi
Maximum Hydraulic flow rate	40 GPM
Mounting (any position)	SAE "A" size, 2 bolt
Shaft Seal Max. Pressure	130 psi

(*) Flow rates below 18 gpm will reduce the blower output (RPM) please contact Buffalo Turbine for more information.

CONTACT BUFFALO TURBINE FOR FLOW RATES THAT EXCEED 40 GPM

It is necessary to warm up the hydraulic vehicle for 5 minutes to get the hydraulic oil up to operating temperature