

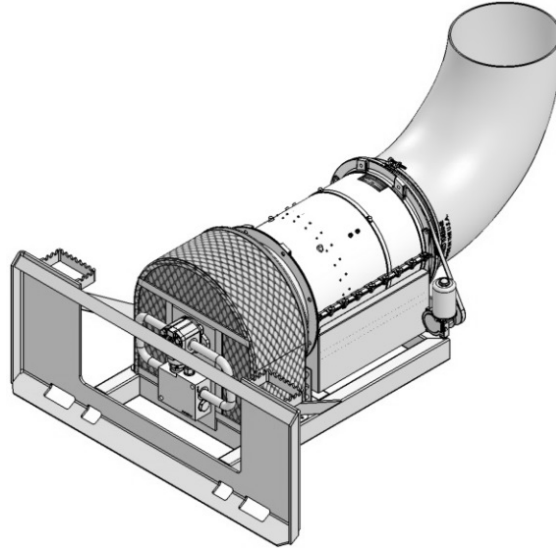

180 Zoar Valley Road • Springville, NY 14141 • Tel: (716) 592-2700 • Fax: (716) 592-2460 • BuffaloTurbine.com



## Hydraulic Debris Blower Model # BT-HYSS3

<b>Warranty</b>	10 Year Manufacturer Warranty
<b>Motor Warranty</b>	2 Year Warranty
<b>Input Power:</b>	Hydraulic motor
<b>Input RPM:</b>	Up to 3600 RPM*
<b>Outlet Size:</b>	12"
<b>Frame Length</b>	39"
<b>Overall Length with Nozzle</b>	64"
<b>Width:</b>	46"
<b>Max Height with nozzle in upright position</b>	32"
<b>Weight:</b>	300 lbs.
<b>Nozzle Rotation:</b>	360°
<b>Hydraulic Motor Displacement size</b>	.915 cu.in./Rev
<b>Required minimum hydraulic pressure (to operate @ stated values)</b>	2900 psi
<b>Maximum Hydraulic flow rate</b>	40 GPM
<b>Mounting (any position)</b>	SAE "A" size, 2 bolt
<b>Shaft Seal Max. Pressure</b>	150 psi
<b>Port location</b>	Side ports

(\* ) Flow Rates below 16 gpm will reduce the blower output (RPM).

Please contact Buffalo Turbine for more information.

CONTACT BUFFALO TURBINE FOR FLOW RATES THAT EXCEED 40 GPM

\*\*It is necessary to warm up the hydraulic vehicle for 5 minutes to get the hydraulic oil up to operating temperature\*\*