

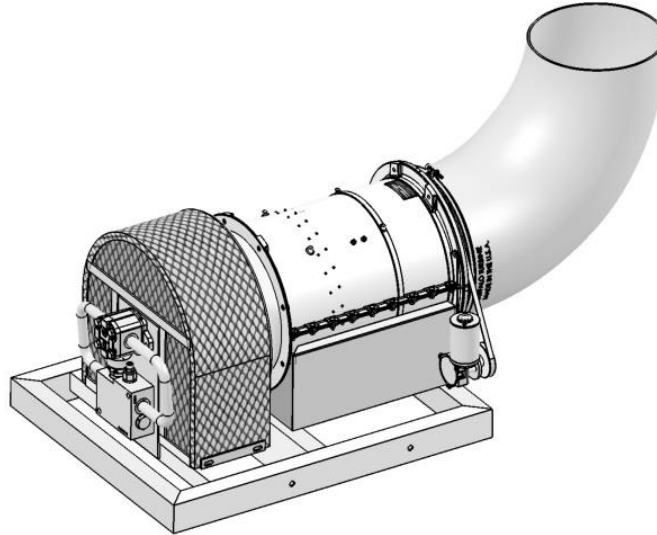

180 Zoar Valley Road • Springville, NY 14141 • Tel: (716) 592-2700 • Fax: (716) 592-2460 • BuffaloTurbine.com



Hydraulic Debris Blower Model # BT-HY3HS

| | |
|---|-------------------------------|
| Warranty | 10 Year Manufacturer Warranty |
| Motor Warranty | 2 Year Warranty |
| Input Power | Hydraulic motor |
| Input RPM | Up to 4100 RPM* |
| Outlet Size | 12" |
| Frame Length | 35" |
| Overall Length with Nozzle | 59" |
| Width | 28.5" |
| Max Height with nozzle in upright position | 32" |
| Weight | Approx. 215 lbs. |
| Nozzle rotation | 360° |
| Hydraulic Motor Displacement size | .918 cu.in./Rev |
| Required minimum hydraulic pressure (to operate @ stated values) | 3100 psi |
| Maximum Hydraulic flow rate | 40 GPM(**) |
| Mounting (any position) | SAE "A" size, 2 bolt |
| Shaft Seal Max. Pressure | 130 psi |

It is necessary to warm up the hydraulic vehicle for 5 minutes to get the hydraulic oil up to operating temperature

(*) Flow Rates below 18 gpm will reduce the Blower output (RPM) please contact Buffalo Turbine for More information.

(**) CONTACT BUFFALO TURBINE FOR FLOW RATES THAT EXCEED 40 GPM



180 Zoar Valley Road • Springville, NY 14141 • Tel: (716) 592-2700 • Fax: (716) 592-2460 • BuffaloTurbine.com
