

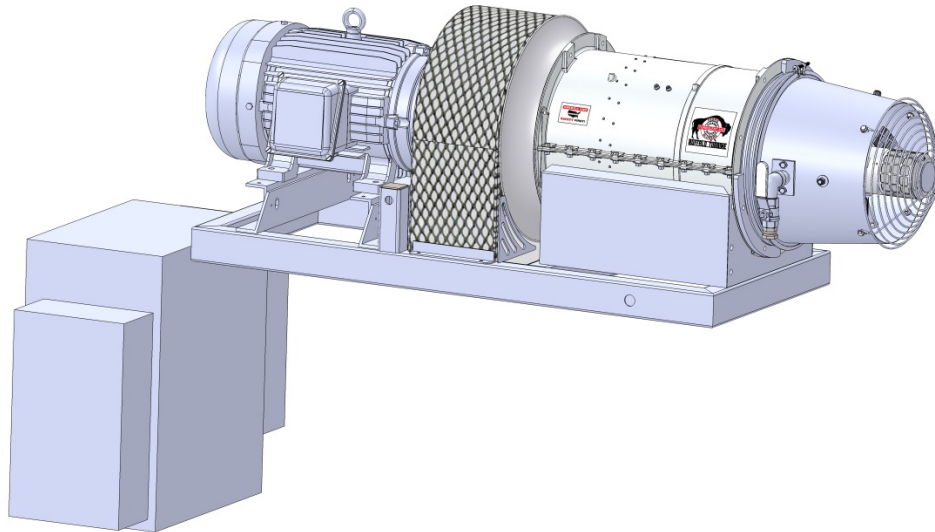

180 Zoar Valley Road • Springville, NY 14141 • Tel: (716) 592-2700 • Fax: (716) 592-2460 • BuffaloTurbine.com



Dust/Odor Controller 460 Volt, Skid Mount Model # BT-EL12M-460

Misting System	Gyratory Atomizing Nozzle
Hose Input	3/4" Utility / Garden Hose
Minimum Water Volume	1/3 Gallon Per Minute
Maximum Water Volume	20 Gallons Per Minute @ 120 psi
Minimum Water Pressure	40 psi
Maximum Water Pressure	120 psi
Droplet size	50-200 Microns
Throw Distance Horizontal	Up to 125 ft. in Neutral Wind Conditions
Throw Distance Vertical	Up to 50 ft. in Neutral Wind Conditions
Warranty	10 Year Manufacturer Warranty
Electric Motor Warranty	2 Year Warranty
Electrical System	460 Volt 3 Phase
Input Power	20 HP Electric Motor
Input RPM	Variable Speed up to 3550 RPM
Outlet Size	12"
Oscillation	3 Settings from 30° to 80°
Frame Length	50"
Overall Length with Nozzle	72"
Width	22"
Max Height with nozzle in upright position	24"
Weight	TBD



WARNING: Cancer and Reproductive Harm – www.P65Warnings.ca.gov

If using a Generator a VFD (variable frequency drive) line reactor is required please contact generator manufacturer